

APPLICATION:

JOB NAME:

QUANTITY: ITEM NO.

PRODUCT NAME:
 PRE-RINSE SPRING STYLE
 SINGLE DECK DUAL CONTROL

_____ SPECIAL CONFIGURATION
 CHECK BASE MODEL AND OPTIONS

MODEL:

2110 ULTRA SPRAY VALVE, NO WALL BRACKET
 2110-WB ULTRA SPRAY VALVE, WALL BRACKET

OPTIONS OR MODIFICATIONS:

SUPPLY LINES (24" OR 36") CIRCLE LENGTH
 ADD-ON FAUCET (6", 8", 10", 12", 14", 16") CIRCLE
 IN-LINE DUAL CHECK VALVE
 BRUSH
 VANDAL RESISTANT KIT
 HANDLES (CROSS OR WRIST) CIRCLE STYLE
 OTHER _____

- FEATURES**
- CONTROL VALVE**
- * SINGLE DECK DUAL CONTROL
 - * INTERNAL SPRING LOADED CHECK VALVES
 - * SWIVELLING SEAT DISKS
 - * HOT SIDE STEM - RIGHT HAND
 - * COLD SIDE STEM - LEFT HAND
 - * STAINLESS STEEL SEATS
 - * STAINLESS STEEL SEAT SCREWS
 - * STAINLESS STEEL HANDLE SCREWS
 - * STAINLESS STEEL BRAIDED INLET HOSES
- HOSE**
- * 36" LENGTH
 - * STAINLESS STEEL END FITTINGS
 - * STAINLESS STEEL EXTERNAL JACKET
 - * 3 PLY FIBER REINFORCED INTERNAL RUBBER HOSE
 - * REPAIRABLE IN FIELD WITH SIMPLE TOOLS
- ULTRA SPRAY VALVE**
- * LOWEST ENERGY USER - 1.15 GPM @ 60 PSI
 - * CLEANS FASTER - TEST PROVEN
 - * ENGINEERED TO LAST - NO 'O' RINGS TO LEAK
 - * INTERCHANGEABLE - FITS ALL BRANDS
- WALL BRACKET**
- * ADJUSTS FROM 2" TO 12"
- SYSTEM LIMITS**
- * TEMP: 40°F MIN. TO 140°F MAX.
 - * PRESSURE: 200 PSI MAX. STATIC
- SHIPPING WEIGHT**
- * 12.0 LBS

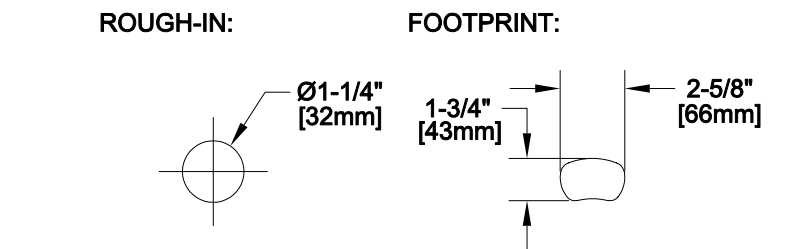
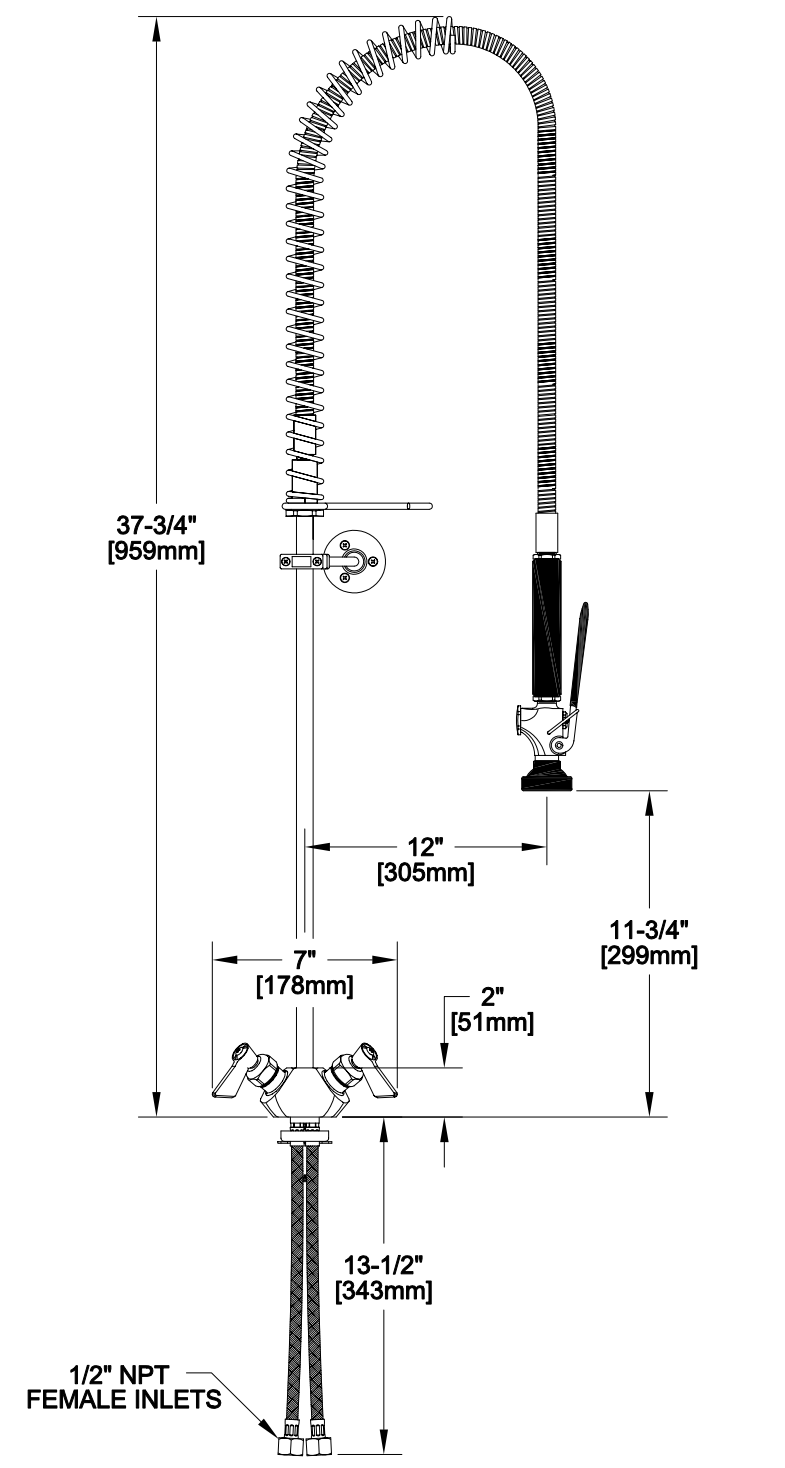

FISHER
 FISHER MANUFACTURING COMPANY
 TOLL FREE: 800-421-6162 - FAX: 800-832-8238
 information@fisher-mfg.com - www.fisher-mfg.com